

SHOWPRO

Atomizer Pro Hazer



User Manual

1. Introduction

Thank you for choosing the Atomizer Pro Hazer. Now you are the owner of the most advanced high-performance haze machine. We kindly suggest you read this manual carefully before using the unit. Abiding by all the instructions will ensure long-term stable and satisfactory effects.

Please follow the operation, safety, and maintenance instructions to ensure the machine operates normally and prolongs its usage life.

Important environmental information about this product

- Do not dispose of the unit or batteries as unsorted municipal waste; it should be taken to a specialized company for recycling.
- This device should be returned to your distributor or to a local recycling service.
- Respect the local environmental rules.
- If there are any doubts, contact with your local waste disposal authorities.
- Thank you for choosing the Atomizer Pro Hazer. If the device was damaged in transit, don't install or use it, and contact your dealer.

2. Product Description

Atomizer Pro Hazer is a haze machine different from a traditional hazer. It adopts high-pressure atomization technology. There is no need for heating, it can be used immediately once the power is on. The machine uses professional matched fluid and is suitable for various indoor performances.



Features:

- High-pressure atomization technology
- Sprays dry and thin haze which spreads fast
- Sprays when powered on, no need to heat up.
- Angle adjustable fan, adjustable fan speed
- Matched with professional fluid

3. Notes Before Use

1. Place the Atomizer Pro Hazer on a stable surface and check whether it is damaged. If damaged, please contact the supplier at once. Unscrew the lid of the fluid tank to pour in the high-quality haze fluid, and then fasten the lid.
2. Before you power on, please verify that the supply voltage conforms with the rated voltage of the haze machine. The power supply should be connected to the grounding wire. When powered on, the indicator light will turn on, and the haze machine will begin to work. Connect the machine to different controllers for alternate control options.
3. At first, it is normal if the hazer creates little smoke or a small amount of steam.
4. Place the Atomizer Pro Hazer in a well-ventilated area, otherwise the machine's temperature fuse will disconnect and cause the unit to stop heating.
5. Place the Atomizer Pro Hazer on the ground horizontally or install it with the mounting bracket, ensuring to keep the unit level. There should be a minimum of 30-centimeters clearance all around the unit. Keep it away from flammable or explosive materials. Keep at least 40cm away from the nozzle to avoid scalding.
6. Do not let the unit run completely out of fluid. If the smoke machine keeps running when the fluid is used up, it will cause damage to the pump and heater. Turn off the power before adding fluid and ensure not to over fill the tank.
7. In the case that the fluid tank is empty, there is noise from the pump, or the machine stops outputting, please disconnect the power at once, and check the fluid level, fuse, cable, and power plug. If the problems are still not resolved, please contact dealer.
8. Do not run the haze machine powered and unattended. Always keep clear of children.
9. Due to condensation, vapor or moisture might gather around the nozzle of the machine. There might be some surplus haze ejected from the haze machine during operation or after shutdown.
10. Please make sure there is no fluid or metals inside the machine before turning on the power each time. Do not modify or repair the machine by yourself. If there are any problems, please contact the dealer.

4. Safety Instructions

- Be very careful during the installation: touching live wires can cause life-threatening electroshocks.
- Keep this device away from rain and moisture.
- Unplug the mains lead before opening the housing.
- Damage caused by disregarding guidelines in this manual is not covered by the warranty and the dealer will not bear responsibility for any ensuing defects or problems.
- A qualified technician should install and service this device.
- Do not switch the device on immediately after it has been exposed to changes in temperature.
- Protect the device against damage by leaving it switched off until it has reached room temperature.
- This device falls under protection class one; it is therefore essential that the device be grounded. Have a qualified person carry out the electric connection.
- Make sure that the available voltage does not exceed the voltage stated in the specification of this manual.
- Do not crimp the power cord and protect it against damage. Have an authorized dealer replace it if necessary.
- Disconnect the device from the mains to clean it or when it is not in use. Handle the power cord by the plug only.
- Note that damage caused by user's modification to the device is not covered by the warranty.
- Keep the device away from children and unauthorized users.

5. General Guidelines

- This device is designed for professional use on the stage, in clubs, theaters, etc. The device should only be used indoors with an alternating current of max. 230V AC/50Hz
- Do not shake the device. Avoid brute force when installing or operating the device.
- Select a location where the device is protected against extreme heat, dust and moisture.
- Familiarize yourself with the functions of the device before actually using it. Do not allow operation by unqualified people. Any damage that may occur will most probably be due to unprofessional use of the device.
- Use the original packaging if the device is to be transported.
- All modification to the device is forbidden for safety reasons.
- Only use the device for its intended purpose. All other usages may lead to short circuits, burns, electroshocks, crashes, etc. Using the device in an unauthorized way will void the warranty.
- This device is not suited for permanent operation. Frequent operation breaks will protect the life span of your haze machine.

6. Installation

- Have the device installed by a qualified person, respecting EN-60598-2-17 and all other applicable norms.
- The carrying construction must be able to support the weight 10 times as heavy as the device for 1 hour without deforming.
- Never stand straight below the device when it is being mounted, removed or serviced. Have a qualified technician check the device once a year and before you bring it into service.
- Install the device in a location with few passers-by that is inaccessible to unauthorized persons.
- Adjusted the desired inclination angle via the mounting bracket and tighten the bracket screws.
- Make sure there are no flammable materials within a 50 cm radius of the device.
- Connect the device to the mains with the power plug.
- The installation must be approved by an expert before the device being taken into service.

7. Use

The smoke machine is controlled by 2 DMX channels:

Channel 1 = haze output channel

Channel 2 = fan output channel

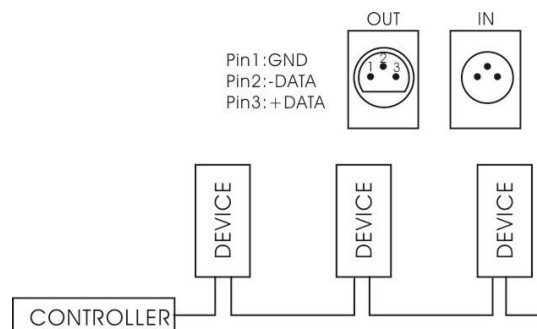

A. DMX 512 Connections

Connect the provided XLR cable to the female 3-pin XLR output of your controller and the other side to the male 2-pin input of the Atomizer Pro Hazer. Multiple Atomizer Pro Hazers can be linked through serial linking. The linking cable should be two core, screened cable with XLR input and output connectors, please refer to the diagram above.

B. DMX 512 Chain with Termination

A DMX terminator is recommended for installation where the DMX cable has to run a long distance or is in an electrically noisy environment (e.g. discos). The terminator prevents corruption of the digital control signal by electrical noise. The DMX terminator is simply an XLR plug with a 120ohm resistor between pins 2 and 3, which is then plugged into the XLR output socket of the last device in the chain. Please see the diagram below.

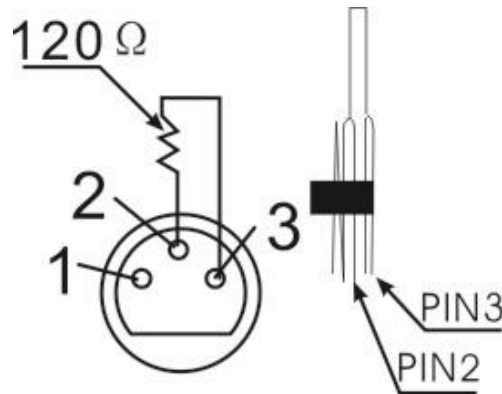

8. Technical Specifications

Power required	AC 220V-240V 50/60HZ
Fuse	5A/250V
Power	500W
Pre-heating time	0min
Smoke output	3000cuft/min
Fluid	Atomizer Fluid: PSHATM125
Tank capacity	3.6L
Oil consumption rate	25h/L
Controller	LCD controller
Fan angle & Wind speed	Adjustable
Weight	35kg
Package size	510*400*360(mm)
DMX-512	Supported



Caution! Safety hazard. Risk of severe injury or death.



Caution! Burn hazard. Hot surface. Do not touch.



Danger! Hazardous voltage. Contact will cause electric shock.



Caution! Fire hazard.